

BD85

CRAWLER DOZER



Salient Features :

- BEML Turbocharged BS6D125-1 Engine
- Power shift Transmission.
- Wet Steering clutches and Brakes
- Arm chair steering control
- Longer track for better stability and improved traction.
- Durable work attachment.
- Segmented sprockets
- Hexagonal ROPS-FOPS Cabin
- Feather touch joy stick control for work attachment gives fatigue free comfort for operator
- The parallel circuit hydraulic system design for precise and responsive control and for efficient simultaneous operation.



BD85

Flywheel Power (FHP) : 172 kW (230 HP) @ 2000 rpm

Operating Mass : 24340 kg

(With Straight tilt Dozer)

www.bemlindia.in

BD85

CRAWLER DOZER

Salient Features :

- **BEML BS6D125-1 Engine:** Engine is environment friendly as it ensures low level of vibration, noise and smoke.
- **Power Shift Transmission :** Smooth and responsive power shift with single lever control for instant speed and directional changes.
- **Control Panel:** Modular type gauges with cluster packaged monitoring system
- **Operator Comfort:** Ergonomically located armchair steering control with patent pending cushion mounting for floor and hexagonal ROPS-FOPS cabin for enhanced operator comfort and excellent visibility.
- **Longer track for better stability and improved traction.**
- **Wet multiple disc steering clutches and brakes :** Foot operated mechanical linkage assisted by hydraulic booster for light touch and easy actuation. Brakes and steering clutches are hydraulically inter connected for easy steering.
- Higher drawbar pull and higher speeds for enhanced productivity.
- **Durable work attachment :** High tensile steel blades of different configurations available to suit varying types of working conditions and applications.
- The attachment is sturdy in construction to withstand adverse ground conditions.
- Rugged driveline components for reliability and longer life.
- Joy stick control work attachment offers effort less pilot controls for all work attachment.



ENGINE

| | |
|--------------------|--|
| Make | BEML |
| Model | BS6D125-1 |
| Type | 6 inline, Diesel 4 stroke, water cooled, turbo charged, direct injection |
| Fly wheel Power | 172 kW (230 HP) @ 2000 rpm in accordance with IS:13116/ISO:9249 |
| Max. Torque | 1010 N-m (103 kg-m) at 1400 rpm |
| No. of Cylinders | 6, inline |
| Bore x Stroke | ∅125 x 150 mm |
| Displacement | 11.04 ℓ (0.01104 m ³) |
| ELECTRICALS | |
| Alternator | 24V, 55 A |
| Starting Motor | 24V, 7.5 kW |
| Battery | 2x12V, 200 Ah |



POWER TRAIN

| | |
|-------------------------|---------------------------------------|
| TORQUE CONVERTER | |
| Stall ratio | 2.2 |
| Type | 3 element, Single Stage, Single phase |
| TRANSMISSION | |
| Type | 3F/3R, Power shift Transmission |



FINAL DRIVE

| | | |
|-----------------------------------|-------------------------------------|------------------|
| Type | Spiral bevel gear, Double reduction | |
| Lubrication | Splash Type | |
| Total Reduction | 17.19 | |
| TRAVEL SPEEDS m/sec (km/h) | | |
| Range | Forward | Reverse |
| 1st | 0-0.972 (0-3.60) | 0-1.134 (0-4.20) |
| 2nd | 0-1.809 (0-6.70) | 0-2.187 (0-8.10) |
| 3rd | 0-3.186 (0-11.8) | 0-3.834 (0-14.2) |



HYDRAULIC SYSTEM

| | |
|---------------------------|---|
| Hydraulic Pump | |
| Type | Tandem gear pump |
| Capacity | 250 ℓpm+19 ℓpm |
| Relief Pressure | 13.73 Mpa (140 kg/cm ²)+2.94 Mpa (30 kg/cm ²) |
| Hydraulic Cylinder | |
| Type | Double acting piston type |
| Blade Lift | 2 Cylinder |
| Bore x Stroke | ∅ 120 mm x 1014 mm |
| Blade Tilt | 1 Cylinder |
| Bore x Stroke | ∅ 160 mm x 140 mm |

STANDARD EQUIPMENT

- Hydraulic Track Adjusters
- Air cleaner inner element lock
- Track roller guard (each side)
- Front Horn
- Lower guard (3 pieces)
- Fixed type draw bar
- Head light & rear light, Gauge lamp switches.
- Front pull hook
- In-line radiator
- Tool kit
- Audio visual backup alarm
- Lighting system (including 4 front and 1 rear lights)
- Straight Tilt Blade
- Seat belt with indicator
- Hexagonal ROPS-FOPS cabin

OPTIONAL ATTACHMENTS

- AC - Heater with Defroster
- Auto fire detection & suppression system
- Rear Vision system
- Multi Shank Ripper
- Angle dozer Blade attachment
- SU Blade
- Coal Dozer Blade
- ROPS Canopy with Sweeper for forestry application
- Warning Systems for operator's fatigue

CONTROL LEVERS

- Steering (Right)
- Steering (Left)
- Gear-shift
- Safety lock for gear shift
- Joy Stick for work attachment
- Fuel control lever
- Brake lock lever
- Safety lock for blade
- Safety lock for blade lever
- Transmission lock lever

METERS GAUGES (LCD DISPLAY)

- Engine oil filter clog
- Torque converter oil temperature
- Engine oil pressure
- Engine oil temperature
- Hour meter, Voltmeter
- Engine speed, Fuel level indicator
- Engine coolant temperature

Warning Indicators

- Engine oil filter clog
- Battery charging (indicator only)
- Engine oil pressure
- Radiator coolant level caution
- Dust indicator
- Smart reverse alarm with flasher unit
- Seat belt indicator

STEERING

| | |
|---------------------|---|
| Type | Wet, multiple disc hydraulic booster, hand operated |
| Min. Turning radius | 3.3 m |
| Steering Control | Arm Chain steering lever |

UNDER CARRIAGE

| | |
|---------------------|--|
| Suspension | Semi rigid Equalizer bar type |
| Track Frame | Box section, high tensile strength steel construction. |
| Track Pitch | 2000 mm |
| Track Rollers | 7 no. each side |
| Carrier Rollers | 2 no. each side |
| Track Shoes | 41 no. each side |
| Grouser Height | 65 mm |
| Shoe Type | Single grouser |
| Shoe width | 560 mm |
| Ground Pressure | 66.13 kPa (0.67 kg/cm ²) (Bare Tractor) |
| Ground contact Area | 3.6065m ² |

FILTRATION

| | |
|---|---|
| Engine | Replaceable cartridge type filter for lubrication as well as for fuel line. |
| Transmission, Torque converter Steering & Brake | Separate replaceable element type filter is provided. |
| Hydraulic System | Magnetic Iron particles separator & return line filters. |

MASS (approximate)

| | |
|---|----------|
| Operating Mass | 24340 kg |
| (Standard equipment with straight tilt dozer) | |
| Shipping Mass | 21420 kg |
| (Basic tractor with lubricants, Hydraulic system, cooling system and 10% of fuel tank capacity) | |

DOZER ATTACHMENT

| Dozer type | Straight | Angle | Semi-U | Coal |
|----------------------------|----------|---------|---------|---------|
| Overall length with dozer | 5915 | 6215 | 5950 | 6565 |
| Blade Length x Height | 3460 | 4260 | 3810 | 4450 |
| | x 1380 | x 1125 | x 1550 | x 1540 |
| Max. Lift above ground | 1350 | 1040 | 1385 | 1625 |
| Max. drop below ground | 620 | 740 | 620 | 545 |
| Max. tilt adjustment | 860 | 600 | 860 | - |
| Blade Capacity (Cum) | 4.5 | 4.31 | 7.50 | 10.10 |
| Additional ground pressure | 8.83 | 9.41 | 9.32 | 9.63 |
| kPa (kg/cm ²) | (0.087) | (0.096) | (0.095) | (0.098) |

MASS in kg

| | | | | |
|------------------------|------|------|------|------|
| Dozer Equipment | 2990 | 3470 | 3440 | 3540 |
| Hydraulic control unit | 450 | 450 | 450 | 450 |

DIMENSIONS mm

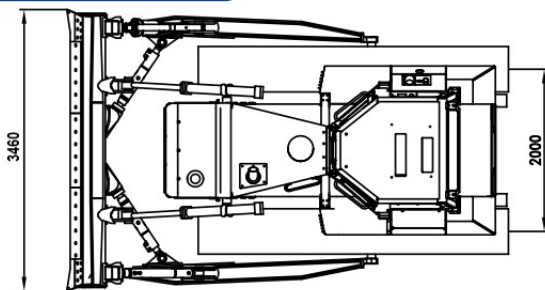

Ground Clearance : 400 mm

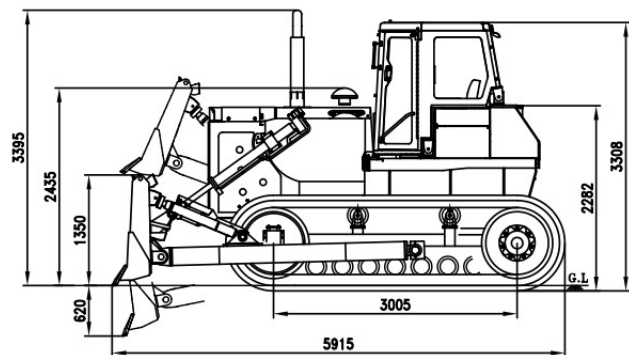

Material and specifications are subject to change without notice, Illustrations may include optional equipment & accessories

SYSTEM FLUID CAPACITY

| System | Refill Capacity (in ltrs.) |
|--|----------------------------|
| Cooling System | 88 |
| Fuel Tank | 385 |
| Engine Oil Pan | 32 |
| Transmission, Torque Converter, Steering, Bevel Gear | 135 |
| Final Drive (each side) | 36 |
| Hydraulic Oil | 114.5 |

BRAKE

| | |
|----------------|---|
| Type | Wet, Contracting Band |
| Actuation Type | Foot operated Mechanical linkage assisted by hydraulic booster for light touch and easy actuation. Brakes and steering clutches are hydraulically interconnected for easy steering. |

CABIN

Hexagonal shaped, sound suppressive ROPS-FOPS cabin provides excellent visibility and operator comfort.

DRAW BAR PULL vs TRAVEL SPEED

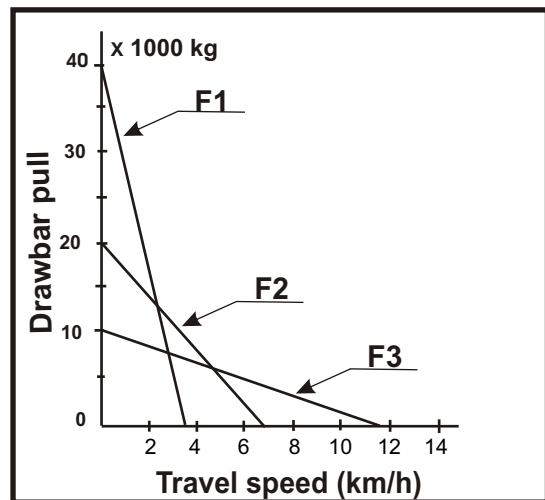

Note: Maximum usable pull depends on traction and weight of equipped tractor.

बी ई एम एल लिमिटेड

BEML LIMITED

Schedule 'A' Company under Ministry of Defence, Govt. of India

Business Network

Corporate Office

BEML Soudha, 23/1, 4th Main,
S.R. Nagar, Bangalore – 560 027

T +91 80 22963240, 22963250

F +91 80 22963278/516/280/164

E-mail: office@cpd.beml.co.in
corpcomm@beml.co.in

International Business Division

Flat No. E,F,G, H, 'Vandana' 11th Floor,
11, Tolstoy Marg, Connaught Place
New Delhi – 110 001

T + 91 11 23316500
F + 91 11 23325085

E-mail: mx@beml.co.in

Marketing Division

5th Floor, Unity Building,
J.C. Road, Bangalore – 560 002

T + 91 80 22963501/02/07/510/540

F + 91 80 22963541

E-mail: m@beml.co.in
mmd@beml.co.in

REGIONAL OFFICES

Bangalore

3rd Floor, Unity Building, J. C. Road,
Bangalore - 560 002
Karnataka

T +91 80 2296 3524
T +91 97413 51588
E-mail: mg@beml.co.in

Bilaspur

1-A, Industrial Area, Sector-C, Sirgitti,
Bilaspur - 495 223.
Chhattisgarh

T + 91 7752 252745, 252598
F + 91 7752 252065
E-mail: mv@beml.co.in

Neyveli

F-4, Dr. Rajendraprasad Road,
Block-27, Neyveli, - 607 803
Tamil Nadu

T/F + 91 4142 268517
T + 91 4142 265517 / 229392
E-mail: ma@beml.co.in

Dhanbad

Mouza - Kangalo, Amaghata,
Govindpur, KG Ashram Post, Dhanbad
Jharkhand – 828 109

T + 91 94711 92023
E-mail: mf@beml.co.in

Hyderabad

3-6-114, Street No.18, Himayat Nagar,
Hyderabad - 500 029
Telangana

T + 91 40 2322 7032 / 94907 93117
F + 91 40 23221794
E-mail: hyderabad@rm.beml.co.in

Kolkata

35/1A, Taratala Road,
Kolkata - 700 088.
West Bengal

T + 91 33 2401 5286 / 87 / 98 / 99
F + 91 33 2401 5288
E-mail: kolkata@rm.beml.co.in

Mumbai

32A, Bazar Road,
Near Jain Mandir, Bandra (West), Mumbai,
Maharashtra - 400 050

T + 91 22 26431875 / 26435875
F + 91 22 26423928
E-mail: mumbai@rm.beml.co.in

Nagpur

No 33, Cement Road,
Shivaji Nagar,
Nagpur - 440 010, Maharashtra.

T + 91 712 2248435 / 2248343
F + 91 712 2249997
E-mail: nagpur@rm.beml.co.in

New Delhi

Flat E,F,G,H, 'Vandana', 11th Floor,
11, Tolstoy Marg, Connaught Place,
New Delhi - 110 001

T + 91 11 2344 3511 / 3528 / 2331 6500
F + 91 11 2332 5085
E-mail: mlm@rm.beml.co.in

Ranchi

206/D-1, Bhagirathi, (Behind NCC Campus)
Rameshwaram Colony, Bariatu Road,
Ranchi, Jharkhand - 834 009

T + 91 651 2540710 / 94311 08531
E-mail: ranchi@rm.beml.co.in

Sambalpur

BEML Complex, NH-6, Panchagachhia,
Baraipalli Post, Sambalpur 768 006
Odisha.

T + 91 663 2521604 / 2521389
E-mail: mb@beml.co.in

Singrauli

PB No. 5, Jhingurdha Colliery,
Singrauli - 486 889
Madhya Pradesh.

T + 91 7805 272668 / 272318
F + 91 7805 272282
E-mail: singrauli@rm.beml.co.in

ACTIVITY CENTRES

Bhopal

Ground Floor, Hall No.1, Chittod Complex, Zone-1,
Maharanapratap Nagar (MP Nagar), Bhopal - 462 011

T + 91 755 2550711 / 8989459753

Panjim

BEML Limited, 5/4, Victor Building, Fontanhas, Mala,
Panjim - 403 001, Goa

T +91 832 2225135 / 77986 87178
E-mail: goa@rm.beml.co.in

Itanagar

C/o. Tobom Riba, H-Sector, Papum
Itanagar – 791 113, Arunachal Pradesh

T + 91 94029 34205 / 88372 15852
E-mail: mcgi@beml.co.in

Kochi

No. 39/2122, Chittoor Road, Ernakulam South,
Kochi – 682 016

T + 91 484 2375138
E-mail: kochi@rm.beml.co.in

Maihar

Maihar, Madhya Pradesh

Mob: +91 79875 53768

Silapathar: Surya Vatika, Amritpur, Silapathar, Assam - 787 059 T +91 95311 29059

DISTRICT OFFICES

Ahmedabad

99/100, BEML HOUSE, 2nd Street,
Azad Society, Ambawadi,
Ahmedabad - 380 015, Gujarat

T + 91 79 26445523 / 94264 13620
F + 91 79 26423950
E-mail: ahmedabad@rm.beml.co.in

Asansol

3, Burnpur Road,
Asansol - 713 304
West Bengal

T + 91 341 2252480
F + 91 341 2250601
E-mail: asansol@rm.beml.co.in

Bacheli

Behind Central Stores of NMDC Ltd.,
Depot 5, Bacheli - 494 553.
Chhattisgarh

T/F + 91 7857 230005
E-mail: bacheli@rm.beml.co.in

Bhilai

Room no 22/C, BSP Expansion Building,
Near Ispat Bhavan, Bhilai 490 001, Chhattisgarh

T + 91 788 2223880
F + 91 788 2221652
E-mail: mnboffice@beml.co.in

Bhubaneswar

252/A, Lewis Road
Bhubaneswar - 751 014
Odisha

T + 91 674 2434427 / 99373 83950
E-mail: mbb@beml.co.in

Chandrapur

Mamidwar, Tiles Factory Compound
Ghugus Road, Padoli
Chandrapur - 442 406 Maharashtra

T + 91 7172 287230
F + 91 7172 287560
E-mail: mnc@beml.co.in

Chennai

Fiat No. 10, Supriya Estates,
No.3, Sterling Road, Nungambakkam,
Chennai - 600 034, Tamil Nadu,

T + 91 44 28220844
F + 91 44 28257319
E-mail: chennai@rm.beml.co.in

Guwahati

No.11, Ward 43, Hengrabari Road,
Ganesh Puri, Dispur,
Guwahati - 781 006 Assam

T + 91 361 2232966
F + 91 361 2232967
E-mail: guwahati@rm.beml.co.in

Hospet

No.1431, Manjunatha Complex,
Bhagat Singh Nagar, Opp. KSSIDC Indl. Estate,
Dam Road, Hospet - 583 203, Karnataka

T/F + 91 8394 230172
E-mail: hospet@rm.beml.co.in

Jammu

62C, Block D/C, Gandhi Nagar,
Jammu tawi - 180 004
Jammu and Kashmir

T + 91 191 2459 437
F + 91 191 2430 447
E-mail: mli@beml.co.in

Kothagudem

Old Project Planning Department,
Near SCCL Corporate Office,
Kothagudem - 507 101, Telangana

T + 91 8744 245572
F + 91 8744 245530
E-mail: kothagudem@rm.beml.co.in

Leh

174-B, (Near Royal Enfield Showroom),
Housing Colony, Leh, Ladakh -194 101

T + 91 1982 258828 / 94198 71008
E-mail : mli@beml.co.in

Ramagundam

Near SCCL TTC, Jawahar Nagar,
Behind CISF Camp, Godavarikhani - 505 209.
Peddapalli Dist.,Telangana

T + 91 8728 248299 / 94408 58441
E-mail: mhr@beml.co.in

Udaipur

20-B, Uchhab Bhavan, Bedla Road,
Fatehpura, Udaipur - 313 001.
Rajasthan

T + 91 294 2452054
E-mail: mwu@beml.co.in

Visakhapatnam

No. 8-45-11, 4th Lane, Vidyanagar Chinna Waltair Colony
Visakhapatnam - 530 003, Andhra Pradesh

T/F + 91 891 2754608 / 83320 54590
E-mail: vizag@rm.beml.co.in

www.bemlindia.in

Represented by:

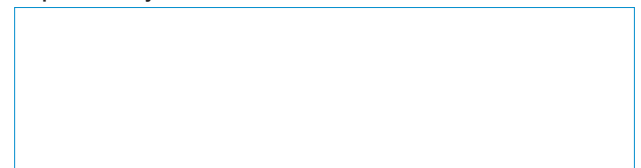

बी ई एम एल लिमिटेड

BEML LIMITED

Schedule 'A' Company under Ministry of Defence, Govt. of India

Crawler Dozers From BEML :

BD50

BD65-1

BD80

BD85

BD155

BD355

BD475

Form No. BD85/01/2020